

RSX1G1624

Ballast Type: Electronic
Input Voltage: 24V AC/DC \pm 20%
Input Frequency: 50/60 Hz. (24VAC)

Starting Method: Preheat Rapid
Lamp Connection: Series
Unit Color: Galvanized

Unit Weight: 0.55 lbs
Carton Quantity: 40
Skid Quantity: 1200

ELECTRICAL SPECIFICATION:

Line Voltage (V)	Lamp Type	Typical Lamp Watts	Approx. Lamp	No. of Lamps	Line Current (A)	Input Power (W)	Power Factor	Max Current THD (%)	Current Crest Factor	Nominal Lamp Current	Wiring Diagram
24	GPH229T5	11	9"	1	0.67	16	≥ 0.98	≤ 10	≤ 1.5	0.48	003
24	GPH254T5	12	10"	1	0.69	16	≥ 0.98	≤ 10	≤ 1.5	0.45	003
24	GPH262T5	13	10"	1	0.71	16	≥ 0.98	≤ 10	≤ 1.5	0.43	003
24	GPH287T5	14	11"	1	0.74	17	≥ 0.98	≤ 10	≤ 1.5	0.40	003
24	GPH305T5	15	12"	1	0.75	17	≥ 0.98	≤ 10	≤ 1.5	0.38	003
24	G16T5	16	11"	1	0.76	17	≥ 0.98	≤ 10	≤ 1.5	0.37	003
24	TUV16W	16	11"	1	0.76	17	≥ 0.98	≤ 10	≤ 1.5	0.37	003
24	TUV16W4P-SE	16	12"	1	0.75	17	≥ 0.98	≤ 10	≤ 1.4	0.38	003
24	LTC18W/2G11	18	8"	1	0.85	20	≥ 0.98	≤ 10	≤ 1.4	0.27	003
24	GPH330T5	16	13"	1	0.79	18	≥ 0.98	≤ 10	≤ 1.4	0.35	003
24	GPH356T5	17	14"	1	0.79	18	≥ 0.98	≤ 10	≤ 1.4	0.30	003
24	GPH357T5	17	14"	1	0.79	18	≥ 0.98	≤ 10	≤ 1.4	0.30	003

PERFORMANCE:

- Electronic ballast
- Preheat rapid start
- Series operation
- High power factor
- Encased & potted
- Sound Rated A
- End-of-Lamp Life Protection
- Internal surge protection

APPLICATION:

- Maximum case temperature: 167°F/75°C
- Maximum ambient temperature: 104°F/40°C
- Minimum starting temperature: 0°F/-18°C
- Not recommended for extreme temperature variations
- Lamp starts: >15,000 starts
- Remote mounting: 18 ft.

SAFETY:

- UL/935 (Class P, Type HL, Type 1 outdoor) listed
- cUL/935 Certified
- Inherent Thermal Protection
- RoHS Compliant
- No PCB's

STYLE:

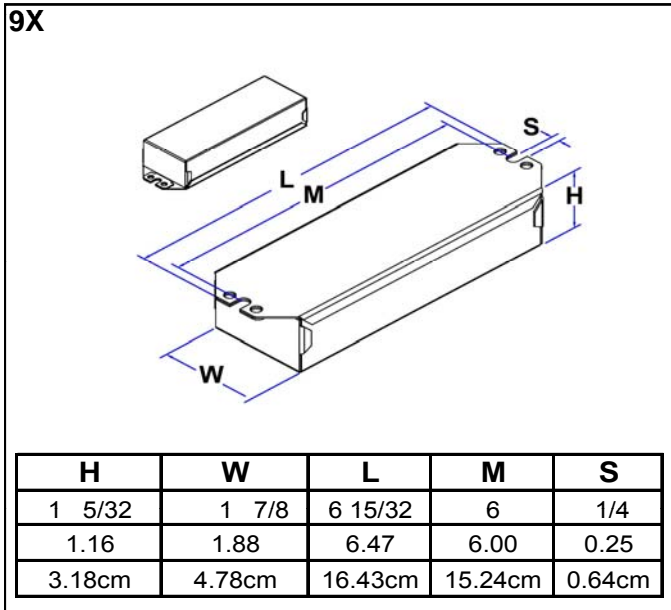

WIRING DIAGRAM:

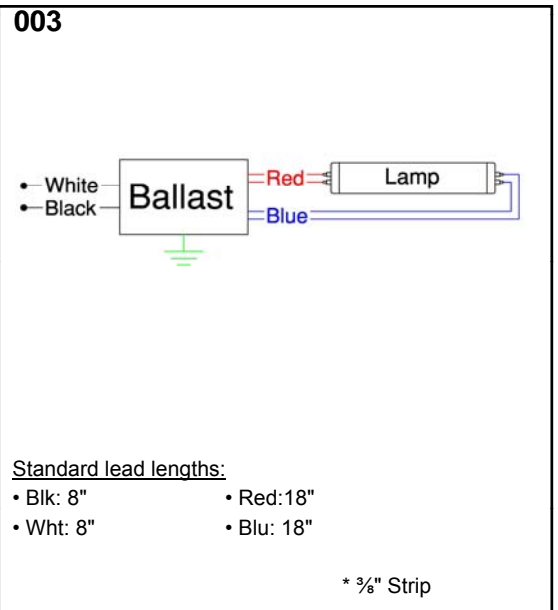

WARRANTY

Robertson Worldwide warrants to the purchaser that this ballast will be free from defects in material or workmanship for a period of 2 years from date of manufacture when properly installed and under normal conditions of use. For more information on Robertson Worldwide's ballasts, call 1-800-323-5633 or visit www.robertsonww.com. Specifications subject to change without notice.

Revised 12/20/10

ROBERTSON WORLDWIDE

13611 Thornton Rd, Blue Island, IL 60406, TEL: 1-800-323-5633, FAX: 1-877-388-2420, www.robertsonww.com