

RSO1GPH40DV

Ballast Type: Electronic
 Input Voltage: 120/230 VAC ± 10%
 Input Frequency: 50/60 Hz.

Starting Method: Preheat Rapid
 Lamp Connection: Series
 Unit Color: White

Unit Weight: .60 lbs
 Carton Quantity: 48
 Skid Quantity: 1536

ELECTRICAL SPECIFICATION:

Line Voltage (V)	Lamp Type	Typical Lamp Watts	Approx. Lamp Length	No. of Lamps	Line Current (A)	Input Power (W)	Power Factor	Max Current THD (%)	Current Crest Factor	Wiring Diagram	B.E.F.
120/230	G30T8	30	35"	1	0.59/0.36	40	≥0.50	≤150	≤1.7	077	/
120/230	GU22-390T5	36	15" U	1	0.55/0.27	35	≥0.51	≤150	≤1.7	077	/
120/230	TUV36PL-L	36	16"	1	0.58/0.30	38	≥0.51	≤150	≤1.7	077	/
120/230	GU76-802T5	37	15" U	1	0.55/0.27	35	≥0.50	≤150	≤1.7	077	/
120/230	GPH793T5	38	31"	1	0.55/0.28	36	≥0.51	≤150	≤1.7	077	/
120/230	GPH810T5	39	31"	1	0.56/0.28	36	≥0.51	≤150	≤1.7	077	/
120/230	G36T6-4	39	33"	1	0.57/0.29	37	≥0.51	≤150	≤1.7	077	/
120/230	GU76-36T5	39	16" U	1	0.58/0.30	38	≥0.50	≤150	≤1.7	077	/
120/230	GU22-36T5	39	17" U	1	0.58/0.30	38	≥0.50	≤150	≤1.7	077	/
120/230	TUV36T5-4P-SE	40	33"	1	0.60/0.32	40	≥0.51	≤150	≤1.7	077	/
120/230	GPH851T5	41	34"	1	0.57/0.29	37	≥0.50	≤150	≤1.7	077	/

PERFORMANCE:

- Electronic ballast
- Preheat rapid start ballast
- Series operation
- Normal power factor
- Encased & potted
- Sound Rated A
- Internal surge protection
- Meets ANSI standard C62.41

APPLICATION:

- Maximum case temperature: 167°F/75°C
- Maximum ambient temperature: 104°F/40°C
- Minimum starting temperature: 0°F/-18°C
- Lamp starts: >15,000 starts
- Remote mounting: 18 ft.

SAFETY:

- UL/935 (Class P, Type HL, Type 1 outdoor) listed
- CSA certified (cUL)
- Inherent Thermal Protection
- RoHS Compliant
- No PCB's

FEATURES:

- LED Lamp on indicator
- Automatic reset thermal protector

STYLE:

7BL

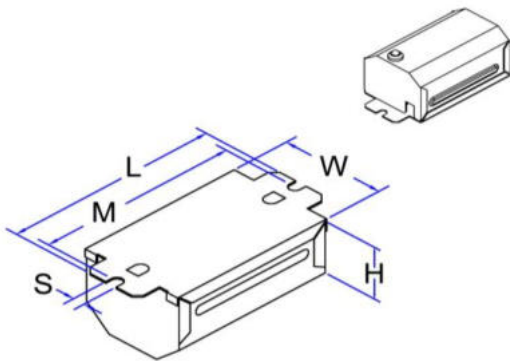

H	W	L	M	S
1 7/16	1 15/16	4	3 3/4	7/32
1.44	1.94	4.00	3.75	0.22
3.66 cm	4.93 cm	10.16 cm	9.53 cm	0.56 cm

WIRING DIAGRAM:

077

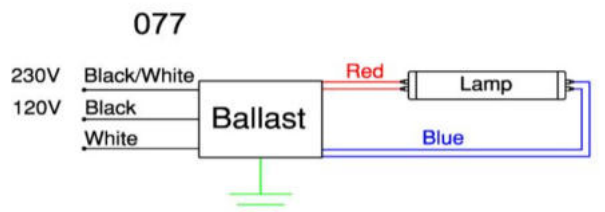

Standard lead lengths:

- Blk/Wht: 6"
- Wht: 6"
- Blk/Wht: 6"
- Red: 15"
- Blu: 15"

* 3/8" Strip

WARRANTY

Robertson Worldwide warrants to the purchaser that this ballast will be free from defects in material or workmanship for a period of 2 years from date of manufacture when properly installed and under normal conditions of use. For more information on Robertson Worldwide's ballasts, call 1-800-323-5633 or visit www.robertsonww.com. Specifications subject to change without notice.

Revised 12/20/10

ROBERTSON WORLDWIDE

13611 Thornton Rd, Blue Island, IL 60406, TEL: 1-800-323-5633, FAX: 1-877-388-2420, www.robertsonww.com