

## IS275P

Ballast Type: Electromagnetic  
 Input Voltage: 120VAC +5%,-10%  
 Input Frequency: 60 Hz.

Starting Method: Instant  
 Lamp Connection: Series  
 Unit Color: Black

Unit Weight: 6.5 lb.  
 Carton Quantity: 6  
 Skid Quantity: 360/288

**ELECTRICAL SPECIFICATION:**

Line Voltage (V)	Lamp Type	Lamp Watts	No. of Lamps	Line Current (A)	Input Power (W)	Power Factor	Max Current THD (%)	Current Crest Factor	Ballast Factor	Wiring Diagram	B.E.F.
120	F96T12	75	2	1.05	115	≥0.90	≤32	≤1.7	0.75	024	0.65
120	F96T12ES	60	2	0.85	93	≥0.90	≤32	≤1.8	0.74	024	0.80
120	F84T12	70	2	0.95	105	≥0.92	≤32	≤1.6	0.74	024	0.70
120	F72T12	57	2	0.85	95	≥0.93	≤32	≤1.6	0.78	024	0.82
120	F64T12	52	2	0.80	94	≥0.93	≤32	≤1.7	0.80	024	0.85
120	F60T12	50	2	0.80	94	≥0.93	≤32	≤1.7	0.80	024	0.85
120	F48T12	40	2	0.58	64	≥0.94	≤32	≤1.9	0.85	024	1.33

**PERFORMANCE:**

- Electromagnetic lead type ballast
- Instant start
- Series operation
- High power factor
- Encased & potted
- Sound rated C
- Meets Public law 100-357
- Meets CSA Standard 654
- Meets ANSI C82.1

**APPLICATION:**

- Maximum case temperature: 194°F/90°C
- Maximum ambient temperature: 104°F/40°C
- Minimum starting temperature: 50°F/10°C
- Minimum starting temperature for ES lamps: 60°F/16°C
- Remote mounting: 10ft.

**SAFETY:**

- UL/935 listed (Class P, Type HL, Type 1 outdoor)
- CSA/C22.2 certified
- Automatic reset thermal protector
- No PCB's

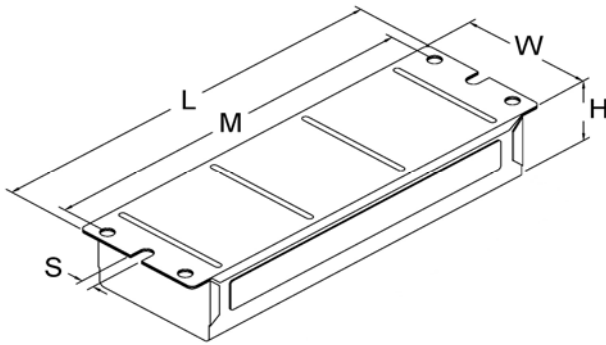
**STYLE:**
**14 & 15**

	H	W	L	M	S
14	1 13/16	3 3/32	9 7/16	8 7/8	5/16
	1.81	3.09	9.44	8.88	0.31
	4.60cm	7.85cm	23.98cm	22.56cm	0.79cm
15	1 13/16	3 3/32	11 11/16	11 1/4	5/16
	1.81	3.09	11.69	11.25	0.31
	4.60cm	7.85cm	29.69cm	28.58cm	0.79cm

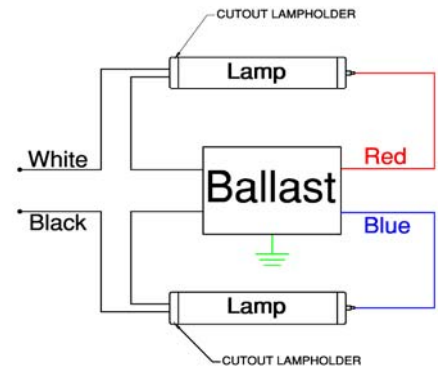
**WIRING DIAGRAM:**
**024**

**Standard lead lengths:**

- Blk: 72"
- Wht: 72"
- Red: 48"
- Blu: 48"
- Yel: 72"

\* 3/8" Strip

**WARRANTY**

Robertson Worldwide warrants to the purchaser that this ballast will be free from defects in material or workmanship for a period of 2 years from date of manufacture when properly installed and under normal conditions of use. For more information on Robertson Worldwide's ballasts, call 1-800-323-5633 or visit [www.robertsonww.com](http://www.robertsonww.com). Specifications subject to change without notice.

Revised 3-30-06

**ROBERTSON WORLDWIDE**

13611 Thornton Rd, Blue Island, IL 60406, TEL: 1-800-323-5633, FAX: 1-877-388-2420, [www.robertsonww.com](http://www.robertsonww.com)