

IEU232T8120

Ballast Type: Electronic
 Input Voltage: 120VAC ±10%
 Input Frequency: 50/60 Hz.

Starting Method: Instant Start
 Lamp Connection: Parallel
 Unit Color: Galvanized

Unit Weight: 0.88 lb
 Carton Quantity: 50
 Skid Quantity: 1750

ELECTRICAL SPECIFICATION:

Line Voltage (V)	Lamp Type	Lamp Watts	No. of Lamps	Line Current (A)	Input Power (W)	Power Factor	Max Current THD (%)	Current Crest Factor	Ballast Factor	Wiring Diagram	B.E.F.
120	F15T8	15	1	0.16	17	≥0.96	≤10	≤1.7	0.92	045A	5.41
			2	0.22	25	≥0.97			0.80		3.20
120	F17T8 F17T8U	17	1	0.19	23	≥0.97	≤10	≤1.7	1.15	045A	5.00
			2	0.26	32				0.90		2.81
120	F25T8 F25T8U	25	1	0.25	30	≥0.98	≤10	≤1.7	1.07	045A	3.57
			2	0.38	45				0.89		1.98
120	F32T8 F32T8U	32	1	0.31	37	≥0.99	≤10	≤1.6	1.05	045A	2.83
			2	0.49	58				0.88		1.52
120	F40T8	40	1	0.38	44	≥0.97	≤10	≤1.6	0.95	045A	2.16

PERFORMANCE:

- Electronic ballast
- Instant Start
- Parallel operation
- High power factor
- Encased & potted
- Sound rated A
- Internal surge protection
- Meets FCC Part 18 (Class B) EMI and RFI consumer limits
- Meets ANSI standard C82.11 and ANSI standard C82.11

APPLICATION:

- Maximum case temperature: 167°F/75°C
- Maximum ambient temperature: 104°F/40°C
- Minimum starting temperature: 0°F/-18°C
- Lamp starts: >15,000 starts
- Remote mounting: 18 ft.

SAFETY:

- UL/935 (Class P, Type HL, Type 1 outdoor) listed
- CSA certified (cUL)
- Inherent Thermal Protection
- RoHS Compliant
- No PCB's

STYLE:

3H

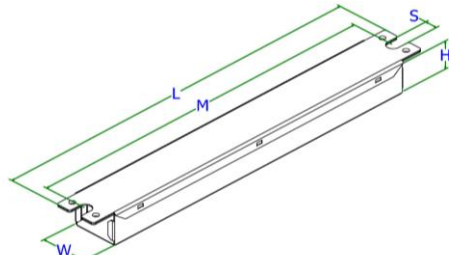

H	W	L	M	S
1 1/16	1 3/16	9 1/2	8 15/16	9/32
1.06	1.19	9.50	8.94	0.28
2.31 cm	2.95 cm	24.13 cm	22.71 cm	0.71 cm

WIRING DIAGRAM:

045A

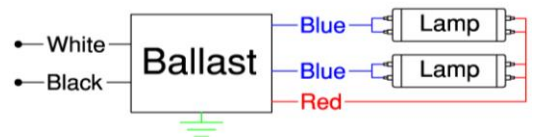

For 1 lamp applications, cap any unused blue lead, insulate 600V

Standard lead lengths:

- Blk: 24"
- Wht: 24"
- Red: 48"
- Blu: (2) 34"

* 3/8 Strip

WARRANTY:

Robertson Worldwide warrants to the purchaser that this ballast will be free from defects in material or workmanship for a period of 5 years from date of manufacture when properly installed and under normal conditions of use. For more information on Robertson Worldwide ballasts, call 1-800-323-5633 or visit www.robertsonww.com. Specifications subject to change without notice.

Revised 12/20/2011

ROBERTSON WORLDWIDE

13611 Thornton Rd, Blue Island, IL 60406, TEL: 1-800-323-5633, FAX: 1-877-388-2420, www.robertsonww.com