

HP28P

Ballast Type: Electromagnetic
 Input Voltage: 120VAC +5%,-10%
 Input Frequency: 60 Hz.

Starting Method: Preheat
 Lamp Connection: Series
 Unit Color: Black

Unit Weight: 1.95 lb.
 Carton Quantity: 15
 Skid Quantity: 480

ELECTRICAL SPECIFICATION:

Line Voltage (V)	Lamp Type	Lamp Watts	No. of Lamps	Line Current (A)	Input Power (W)	Power Factor	Max Current THD (%)	Current Crest Factor	Ballast Factor	Wiring Diagram	B.E.F.
120	CFQ26W/G24d, CFTR26W/GX24d	26	1	0.26	31	≥0.93	≤30	≤1.7	0.90	102	2.9

PERFORMANCE:

- Electromagnetic lead type ballast
- Preheat start
- Series operation
- High power factor
- Encased & potted
- Sound rated A
- Meets ANSI C82.1

APPLICATION:

- Maximum case temperature: 194°F/90°C
- Maximum ambient temperature: 104°F/40°C
- Minimum starting temperature: 25°F/-4°C
- Remote mounting: 10 ft.

SAFETY:

- UL listed (Class P, Type HL, Type 1 outdoor)
- CSA/C22.2 Certified
- Automatic reset thermal protector
- No PCB's
- RoHS Compliant

STYLE:

10

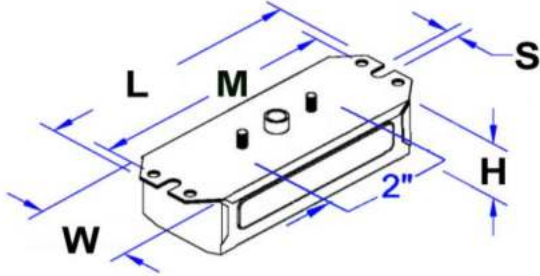

H	W	L	M	S
1 11/16	2 3/8	6 9/16	6	5/16
1.69	2.38	6.56	6.00	0.31
2.71 cm	6.03 cm	16.66 cm	15.24 cm	0.79 cm

WIRING DIAGRAM:

102

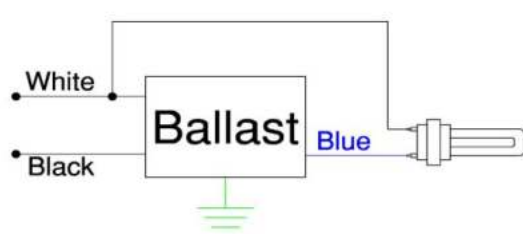

Standard lead lengths:

- Blk: 12"
- Blu: 12"
- Wht: 12"

* 3/8" Strip

WARRANTY

Robertson Worldwide warrants to the purchaser that this ballast will be free from defects in material or workmanship for a period of 2 years from date of manufacture when properly installed and under normal conditions of use. For more information on Robertson Worldwide's ballasts, call 1-800-323-5633 or visit www.robertsonww.com. Specifications subject to change without notice.

Revised 12/17/10

ROBERTSON WORLDWIDE

 13611 Thornton Rd, Blue Island, IL 60406, TEL: 1-800-323-5633, FAX: 1-877-388-2420, www.robertsonww.com