

PSR2GPH55HOMV

Ballast Type: Electronic
 Input Voltage: 120-277VAC ±10%
 Input Frequency: 50-60Hz

Starting Method: Program Start
 Lamp Connection: Series

Unit Color: Black
 Unit Weight: 1.90 lbs.

ELECTRICAL SPECIFICATIONS:

Line Voltage (V)	Lamp Type	Lamp Watts	Approx. Lamp Length	No. of Lamps	Arc Voltage (V)	Lamp Current (mA)	Line Current (A)	Input Power (W)	Power Factor
120	GPH508T5HO	51	20"	2	64	800	0.82	98	≥ 0.98
277							0.35		
120	GPH508T5HO	51	20"	1	64	800	0.43	53	≥ 0.98
277							0.19		
120	GPH436T5HO	42	17"	2	53	800	0.68	82	≥ 0.98
277							0.30		
120	GPH436T5HO	42	17"	1	53	800	0.36	45	≥ 0.98
277							0.16		
120	GPH406T5HO	41	16"	2	51	800	0.66	80	≥ 0.98
277							0.28		
120	GPH406T5HO	41	16"	1	51	800	0.35	42	≥ 0.98
277							0.15		
120	GPH841T5HO	90	33"	1	112	800	0.74	88	≥ 0.98
277							0.32		

PERFORMANCE:

- Max Current THD = ≤ 10%
- Current Crest Factor = ≤ 1.7
- High Power Factor
- Normal Ballast Factor
- Encased & Potted
- Sound Rated A
- Meets FCC Part 18 (Class A) for EMI and RFI non-consumer limits
- Meets DoE Consumer Limits
- Meets ANSI Standard C62.41 for Transient Protection
- Meets ANSI Standard C82.11 for Ballast Requirements

APPLICATION:

- Maximum Case Temperature: 194°F/90°C
- Maximum Ambient Temperature: 140°F/60°C
- Minimum Starting Temperature: -22°F/-30°C
- Lamp Starts: > 50,000 Starts
- Remote Mounting: 18 ft. Max. Lead Length, 18AWG

SAFETY/STANDARDS:

- UL/935 Listed (Class P, Type 1 Outdoor)
- CSA/C22.2 Certified
- No PCB's, Type HL, Type CC
- RoHS Compliant

U.S. PATENT NUMBERS:

6,366,032 B1 ; 6,420,838 B1 ; 5,436,529

CASE STYLE: CS-12

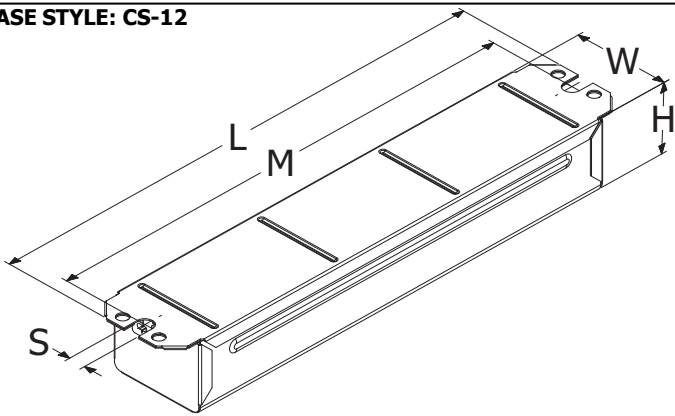

L	W	H	M	S
9 7/16	1 7/8	1 7/16	8 7/8	5/16
9.44	1.88	1.44	8.88	0.31
23.98 cm	4.78 cm	3.66 cm	22.56 cm	0.19 cm

WIRING DIAGRAM:

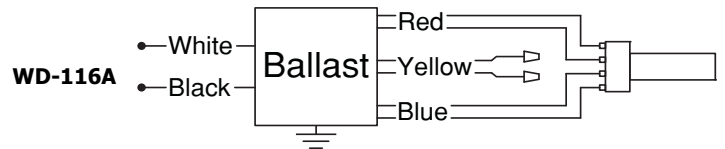

For 1 Lamp Application Cap Unused Yellow Lead,s
 Insulate to 600 Volts

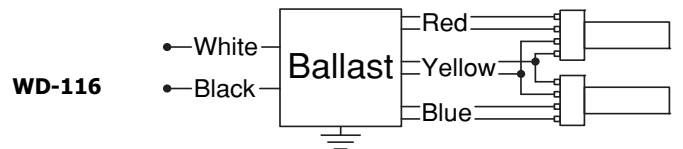

- Black: 12"
 - White: 12"
 - Red: (2) 26"
 - Blue: (2) 26"
 - Yellow: (2) 26"
 - Strip: 0.375" ± 0.060"
- Tolerance: +1.00, -0.50"
 Tolerance: +2.00, -1.00"

WARRANTY:

Robertson Worldwide warrants to the purchaser that this product will be free from defects in material or workmanship for a period of 5 years from date of manufacture when properly installed and under normal condition of use. Specifications subject to change without notice.

For more information on Robertson Worldwide products, visit www.RobertsonLighting.com