

HP213P

Ballast Type: Electromagnetic
 Input Voltage: 120VAC+5%,-10%
 Input Frequency: 60 Hz.

Starting Method: Preheat
 Lamp Connection: Parallel
 Unit Color: Galvanneal

Unit Weight: 1.44/1.51 lb
 Carton Quantity: 24
 Skid Quantity: 960/800

ELECTRICAL SPECIFICATION:

Line Voltage (V)	Lamp Type	Lamp Watts	No. of Lamps	Line Current (A)	Input Power (W)	Power Factor	Max Current THD (%)	Current Crest Factor	Ballast Factor	Wiring Diagram	B.E.F.
120	CFT13W/GX23, CFQ13W/GX23	13	2	0.28	33	≥0.90	≤30	≤1.5	0.90	138	2.73

PERFORMANCE:

- Electromagnetic reactor type ballast
- Preheat start
- Parallel operation
- High power factor
- Encased & potted
- Sound rated A
- Meets ANSI standard C82.1

APPLICATION:

- Maximum case temperature: 194°F/90°C
- Maximum ambient temperature: 104°F/40°C
- Minimum starting temperature: 32°F/0°C
- Remote mounting: 10ft.

SAFETY:

- UL/935 (Class P, Type HL, Type 1 outdoor)
- Automatic reset thermal protector
- No PCB's
- RoHS Compliant

STYLE:

8

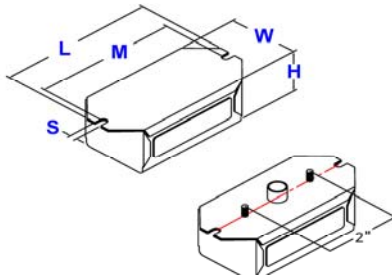

H	W	L	M	S
1 5/8	2 3/16	4 3/4	4 3/8	7/32
1.63	2.19	4.75	4.38	0.22
4.14cm	5.56cm	12.07cm	11.13cm	0.56cm

9

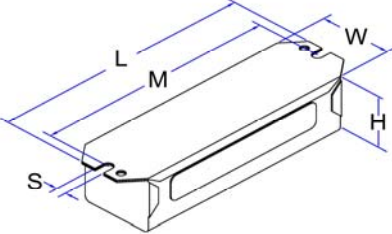

H	W	L	M	S
1 13/32	1 29/32	6 7/16	6	1/4
1.41	1.91	6.44	6.00	0.25
3.58cm	4.85cm	16.36cm	15.24cm	0.64cm

WIRING DIAGRAM:

138

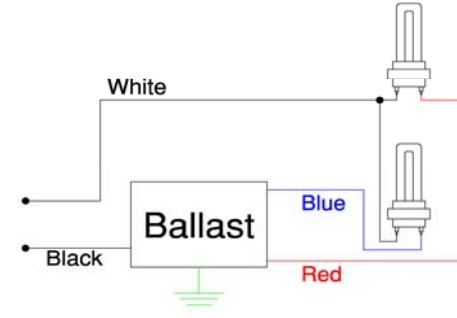

Standard lead lengths:

- Blk: 8"
- Blu: 8"
- Red: 8"

* 3/8" Strip

WARRANTY

Robertson Worldwide warrants to the purchaser that this product will be free from defects in material or workmanship for a period of 2 years from date of manufacture when properly installed and under normal condition of use. Specifications subject to change without notice.

For more information on Robertson Worldwide products, visit www.RobertsonLighting.com